

EJOT® ADJUSTtec

Adjustment element "standard"

Many car manufacturers use adjustable rear lights in order to ensure identical clearances in the auto body.

To meet this requirement EJOT developed a component comprised of plastic nut and double ended stud, which can be pre-adjusted to a size specified by the customer.

The adjustment element ADJUSTtec "standard" is self-tapping, and it is fastened with the hexagon drive of the plastic nut into the screw boss of the rear light.

The rear light, already equipped with these elements, can then be fastened with only a few manual steps directly at the production line. The adjustment of the rear light is done by tightening or loosening the double ended stud.

If the pre-adjusted size does not achieve the desired clearances at the vehicle, they can be easily adjusted.



Application range

- Fastening and adjustment of rear lights e. g. Ford Focus, Seat Altea etc.
- Fastening and adjustment of add-on parts (bumper, spoiler)

Advantages of adjustment element

- Pre-assembly to the add-on part possible
- Fast assembly at the production line
- Pre-adjusted, ready-to-install element
- Subsequent adjustment possible
- No screw thread in the screw boss required
- Variable torque
- Weight reduction through the use of a plastic hollow screw
- Large adjusting range

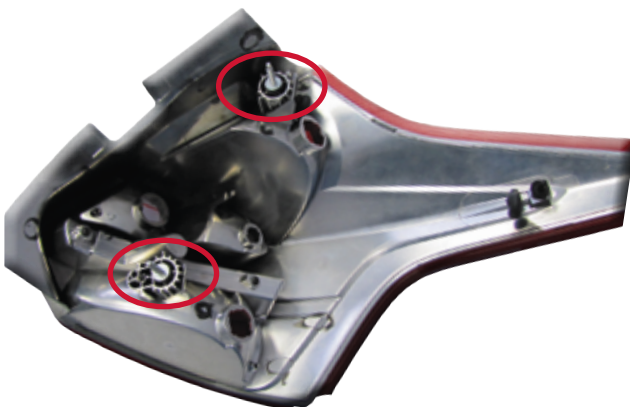

Technical information

Dimensions	Total length of the component [mm]	Connection Light casing (self-tapping)	Assembly drive	Connection Auto body	Pre-adjustment [mm]	Adjusting range [mm]	Prevailing torque [Nm]		Adjustment drive [mm]	Component weight [g/pc.]
							Value	Tolerance		
	A	C	D	B	H				G	
50x17 / Ø5.2x14.4	31.4	Special thread Ø10	A/F 17	Snap-fit element	6.1 ± 0.25	2	1.2	min.	A/F 10	7.95
50x21.1 / M6x28	49.1	Special thread Ø10	A/F 17	M6	9.5 ± 0.25	6	1.6	± 0.4	TORX® E5	14
50x21.1 / M6x28	49.1	Special thread Ø10	A/F 17	M6	6.5 ± 0.25	6	2.1	± 0.9	TORX® E5	14
50x21.1 / M5x18	39.1	Special thread Ø10	A/F 13	M5	7.0 ± 0.25	6	1.6	± 0.4	TORX® E4	7.9
50x21.1 / M5x38	59.1	Special thread Ø10	A/F 13	M5	6.3 ± 0.20	6	1.6	± 0.4	TORX® E4	7.9

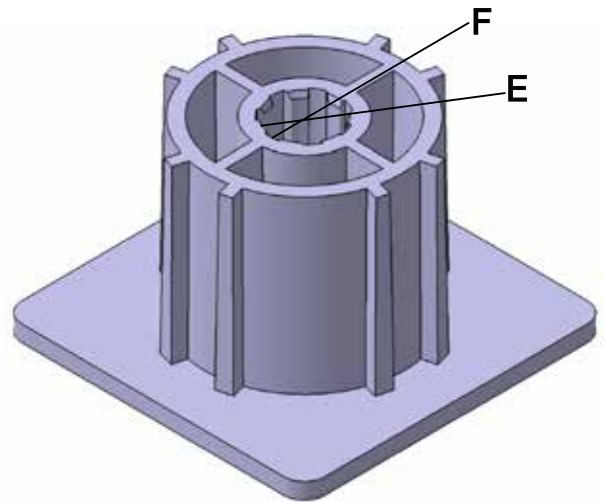
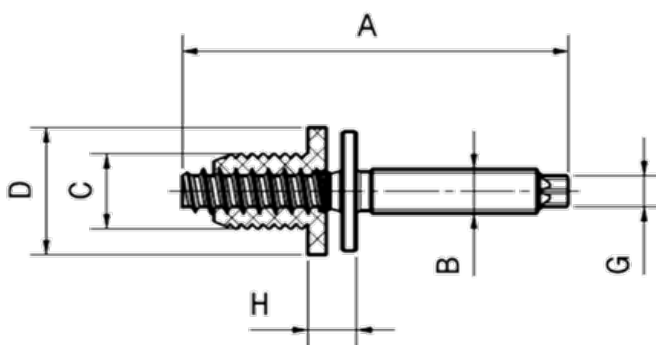

Installation instruction / boss design

- Screw boss rear light according to the installation recommendation:**
 Diameter E = Ø 8.9 mm
 Diameter F = Ø 9.6 mm
- Installation rotation speed:**
 n = 500 rpm
- Axial contact pressure:**
 F = 50 - 100 N (mandatory)
- Fastening element:**
 Hex nut, preferably according to DIN 6923