

EJOT DELTA PT® P

Weight savings with the correct choice of fastener

The lay out design for the direct assembly of steel screws with thermoplastic material often shows that unreinforced materials such as PA6, PP or ABS often have considerably lower strength properties than the fastener itself.

In order to equalise the two material strengths it makes sense to match the screw material with the material to be fastened. For this reason plastic material, in addition to aluminium, should be considered.

As a possible solution for this, the EJOT design engineers developed a DELTA PT® screw made of plastic. With this screw made of PPA GF50 material the unreinforced plastics can be installed self-tapping.

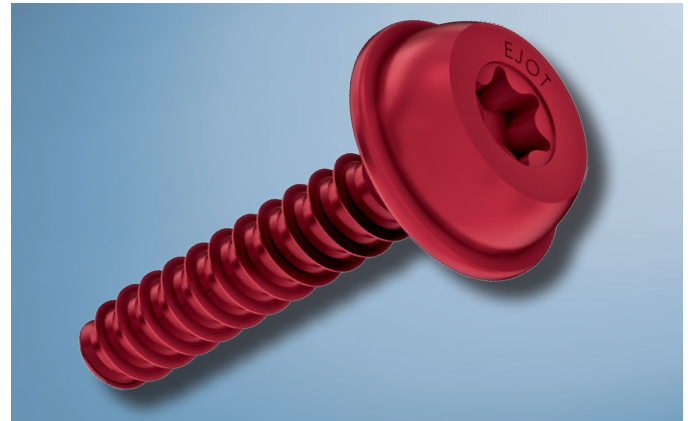

Advantages of the different materials:

1. DELTA PT® P made of plastic material

- | Maintaining the clamp load under thermal influence
- | Weight reduction
- | No corrosion
- | Variable in length
- | Recyclable
- | High insulation resistance
- | Coefficient of expansion similar to plastic

2. DELTA PT® made of aluminium

- | Maintaining the clamp load under thermal influence
- | Weight reduction
- | Coefficient of expansion similar to plastic
- | Non-magnetic

3. DELTA PT® made of steel

- | High strength properties
- | Fatigue strength
- | DELTA CALC prognosis programme available
- | Cost-effective



DELTA PT® P 50x25 fastened in PMMA



Weight comparison of the screw material

Range of applications



1. Plastic Material

Unreinforced soft thermoplastics such as ABS, PP or Polyamid. The screw joint is designed for low clamp loads under minimal relaxation and extreme weight savings.

2. Aluminium

Suitable for thermoplastics of up to medium strength, where non-magnetic fastening elements are needed. Simultaneous maintaining of the clamp load under thermal influence.

3. Steel

Unreinforced and reinforced thermoplastics where high clamp loads and driving forces are necessary. Clamp load oriented design with the DELTA CALC prognosis programme.

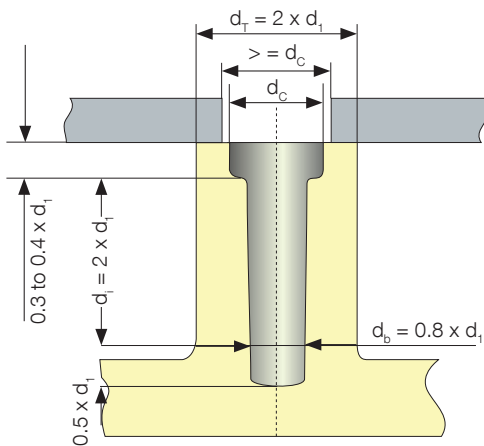

Design recommendations EJOT DELTA PT® P

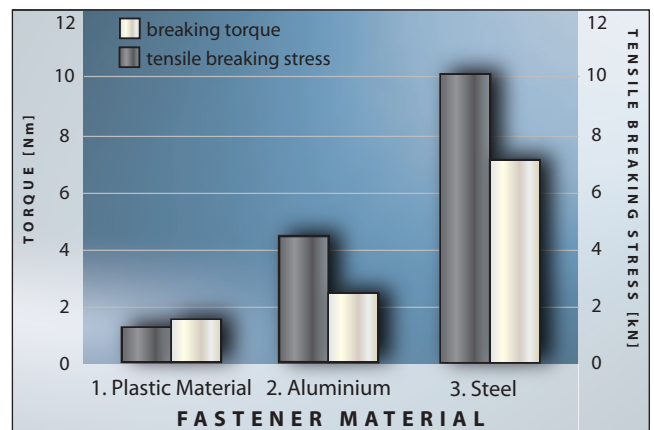

Comparison of the breaking torque and the tensile

Comparison of the installation and stripping torque as well as pull-out load in different materials

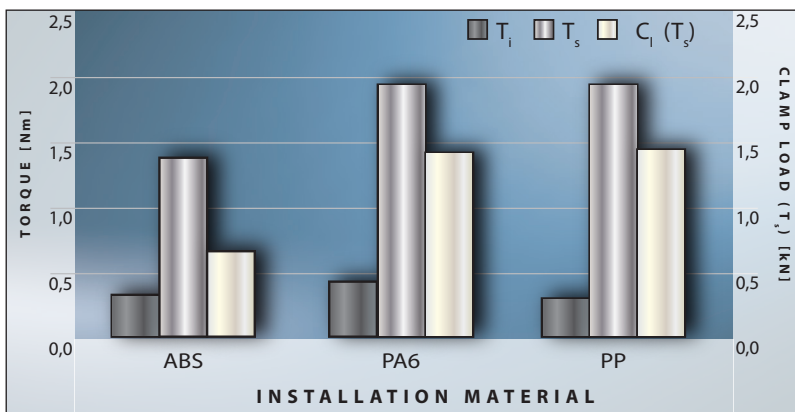

Screw: EJOT DELTA PT® P 50x25 - Installation depth: 10 mm - Hole diameter: 4 mm